

# Scénologic

Modular demountable  
tiered seating system



A versatile, portable  
and aesthetic solution

Our tiered seating system was developed in partnership with performing arts companies working with smaller audiences. Our specification was to create a demountable, portable and compact seating solution, for use on stages and in a variety of non-specialized locations: playgrounds, multipurpose halls, art centres... We wanted our partners to be able to transport their seating, decor and sound and light equipment in a single light vehicle.

We developed an innovating, lightweight, easy to assemble and dismount and storable solution, built from aluminium profiles, 3 times lighter than steel equivalents.



Our first prototype in our workshop in Marseille (2013)

3-row

Small volume for storage and transport.  
Ideal for young audiences.

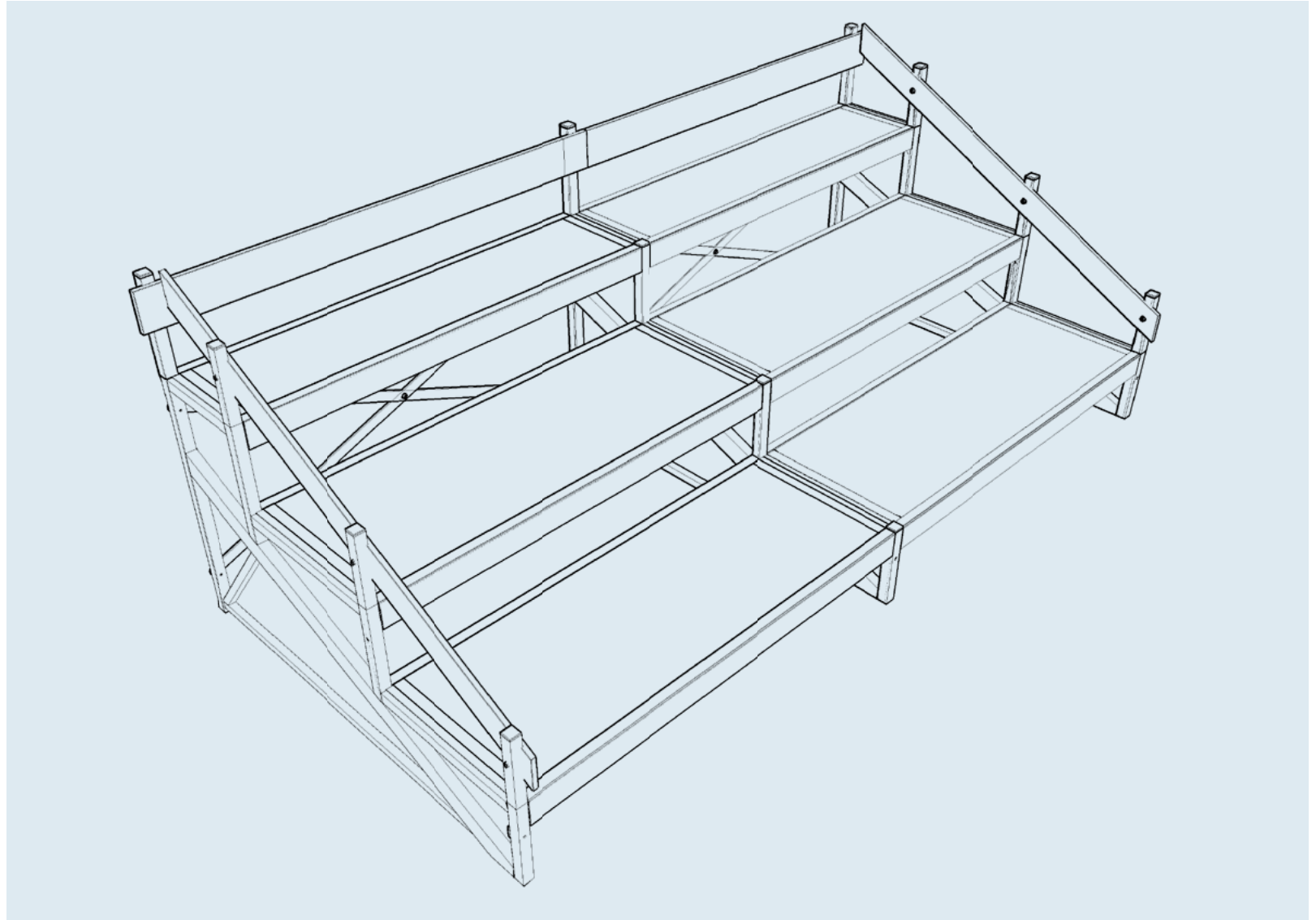

2 3R modules, 21 seats

4-row

76 cm deep seats.  
Can be combined with 45° angle modules.

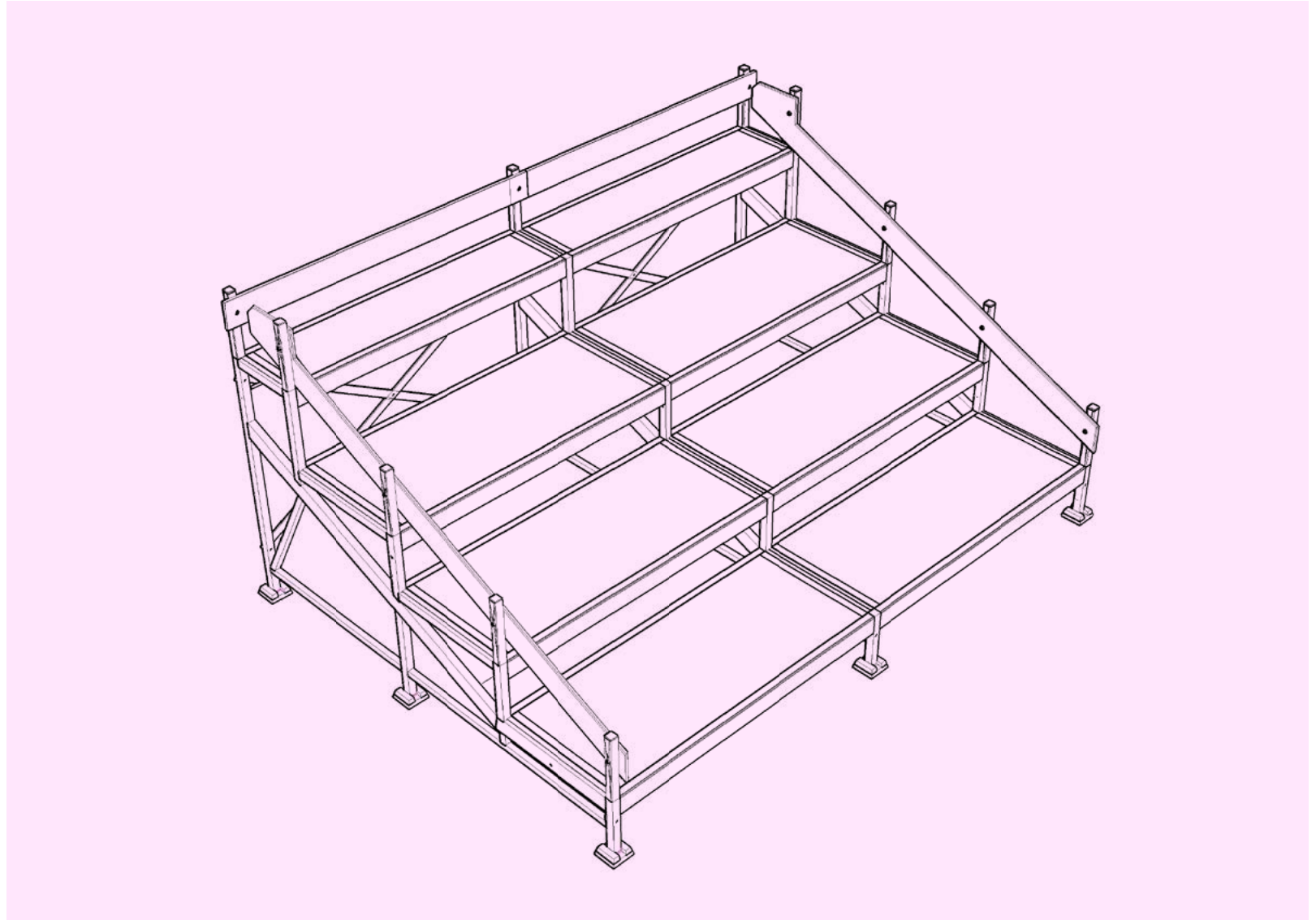

2 4R modules, 28 seats

4-row: 45° modules

Trapezoid shaped modules (4-row only)  
allow for curved and circular configurations.

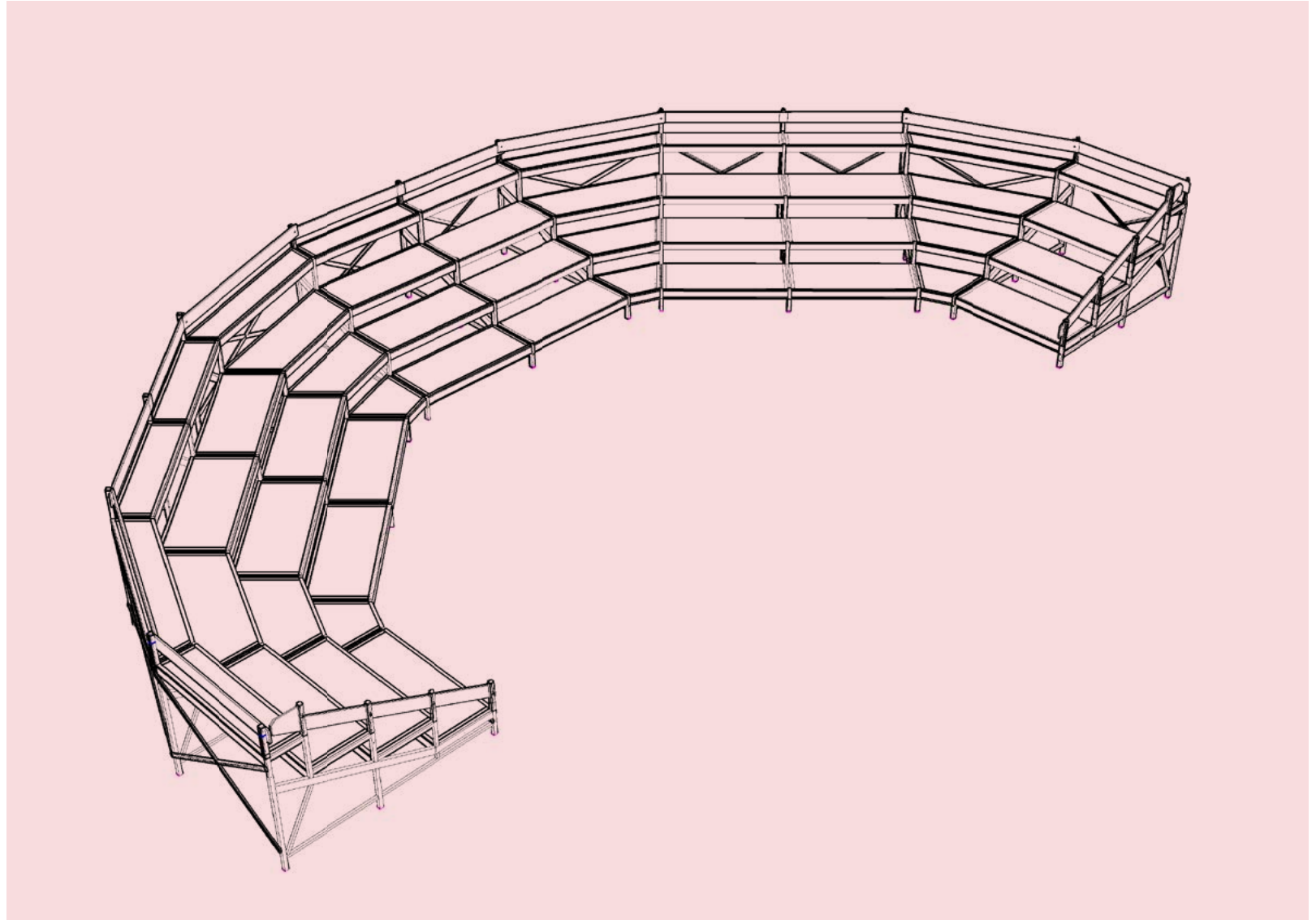

8 4R modules + 4 M45 modules, 160 seats, total width 9,75 m

## Storage racks

Our painted steel racks are equipped with 4 swivel casters (20 cm diameter), allowing for easy manoeuvres. Measurements are calculated to accommodate standard 90 cm doors (3 and 4-row model only). The racks can also be moved on a forklift.

Total weight examples for  
4-row modules stored on racks :

4 modules, 56 seats  
2 racks, 450 kg

6 modules, 84 seats  
3 racks, 700 kg

2 x 4 modules, 112 seats  
3 racks, 900 kg

2 x 6 modules, 168 seats  
4 racks, 1 300 kg

3 x 4 modules, 168 seats  
5 racks, 1 375 kg

3 x 6 modules, 252 seats  
6 racks, 1 975 kg



6 4R modules + 2 M45 modules, 108 seats, total weight 725 kg. Fits in a 20m<sup>2</sup> light vehicle.

## References



Le Séchoir, scène andémik de Saint-Leu, La Réunion



Le Ciel, la Nuit et la Fête (Psyché), Nouveau Théâtre Populaire, 2021. C. Raynaud de Lage/Festival d'Avignon



## Venues

- Abbaye Cistercienne de l'Escaladieu, Bonnemazon
- Le Carré Sainte-Maxime
- Centre chorégraphique national de Rillieux-la-Pape
- Comédie Poitou-Charentes, Centre dramatique national, Poitiers
- Espace culturel Capellia, La Chapelle-sur-Erdre
- Maison du Brie, Meaux
- Les Scènes du Jura, Scène nationale, Dole
- Le Séchoir, Scène nationale, Saint-Leu, La Réunion
- Tandem Centre d'animation, Beaulieu Maladrerie, Caen
- Théâtre Allegro, Miribel
- Théâtre de Ramonville
- Théâtre du Rivage, Saint Jean de Luz
- Théâtre du Vellein, Villefontaine
- Théâtres en Dracénie, Draguignan

## Companies

- A K Entrepôt, Saint-Brieuc
- Agence de voyages imaginaires, Marseille
- Compagnie 3637, Brussels
- Compagnie ACTA, Villiers-le-bel
- Compagnie Sans Soucis, Caen
- Konpani Ibao, Le Port, La Réunion
- naphtaline, Lausanne
- Nouveau Théâtre Populaire, Fontaine-Guérin
- Soy Création, Paris
- Théâtre de Cuisine, Marseille
- Le Vent des Forges, Montreuil le Gast

## Communities and associations

- Centre dramatique des Villages du Haut Vaucluse, Valréas
- Conseil départemental du Territoire de Belfort
- DGA Education Culture, département du Calvados, Caen
- Le Havre Seine Métropole
- Ligue Corse de Squash, l'Île Rousse
- Mauges Communauté, Beaupréau
- Le Tout-Petit Festival, communes d'Erdre & Gesvres
- Service des affaires culturelles, mairie de Villiers-le-bel



Théâtre du Vellein



## Technical specifications



### Materials

Aluminium profiles.  
Vitrified spruce Plywood, matte finish

### Measurements

3-row:  
seating height 33, 66 & 99 cm,  
width 175 cm, depth 172 cm.

4-row:  
seating height 33, 66, 99 & 145 cm  
width 175 cm, depth 260 cm.

### Capacity

50 cm / seat  
1 2R module: 7 seats  
1 3R module: 10,5 seats  
1 4R module: 14 seats  
1 M45 module: 12 seats

### Configurations

Frontal, bi-frontal and tri-frontal configurations.  
half and full circles (4-row model only).

### Weight calculation base

500 kg / m<sup>2</sup>

### Design and production

Design by Patrick Vindimian.  
Engineering consultant: Benoît Probst, Art et Oh.  
Compliance inspection: Richard Gil, Diversis.  
Production: Atelier de l'Evènement.

### Certification

Certified to European standard EN 13200  
for removable seating stands.

Scénologic

Scénologic develops innovating stage equipment. Our solutions are hybrid forms, inspired by architecture, industrial design and visual art. Our approach combines 3D modeling with our long-term practice of decor building and our experience of touring production. We use this creative and technical knowledge to research optimal production processes, allowing us to propose accessible prices while keeping up to a rigorous standard of quality and aesthetic consistency.

L'Atelier de l'Évènement

L'Atelier de l'Évènement is a well-established production company specializing in decor building and scenography, fully equipped with cutting edge tools for aluminium construction.



Patrick Vindimian (r) and Sylvain Georget (l)

## Contact information

[www.scenologic.com](http://www.scenologic.com)

Patrick Vindimian  
+33(0)6 62 36 20 73  
[patrick.vindimian@latelier.events](mailto:patrick.vindimian@latelier.events)

L'Atelier de l'Événement  
75 rue de la Plaine  
75020 Paris

[www.latelier.events](http://www.latelier.events)

SIRET 498 532 365 00026  
TVA intracommunautaire FR85 498 532 365

